



OMAL[®]
AUTOMATION

EMPOWERED PERFORMANCE

SUPREME TRUNNION

CATALOGUE



www.omal.com



VALVOLE A SFERA · INDICE 2/3

Pag:



1.6

• SUPREME - TRUNNION

303

- DN \leq 100 SIZE \leq 4" – ANSI 150-300
- DN \leq 100 SIZE \leq 4" – ANSI \geq 600
- DN \geq 150 SIZE \geq 6"
- Taglie e Accessori SUPREME - TRUNNION
- Componenti SUPREME - TRUNNION
- Dimensioni valvole passaggio totale
- Azionamenti disponibili

304

306

308

311

313

316

318



1.6.1

- Certificati SUPREME - TRUNNION 

320



BALL VALVES · INDEX 2/3

Pag:



1.6

• SUPREME - TRUNNION

303

- *DN ≤ 100 SIZE ≤ 4" – ANSI 150-300* 304
- *DN ≤ 100 SIZE ≤ 4" – ANSI ≥ 600* 306
- *DN ≥ 150 SIZE ≥ 6"* 308
- *Sizes and Accessories SUPREME - TRUNNION* 311
- *Components SUPREME - TRUNNION* 313
- *Full bore valves - Dimensions* 316
- *Available Drivers* 318

1.6.1

- *SUPREME - TRUNNION Certificates*  320





1.6

SUPREME TRUNNION

SUPREME



SUPREME

VALVOLA A SFERA TRUNNION

TRUNNION BALL VALVE

DN ≤ 100 SIZE ≤ 4" – ANSI 150-300

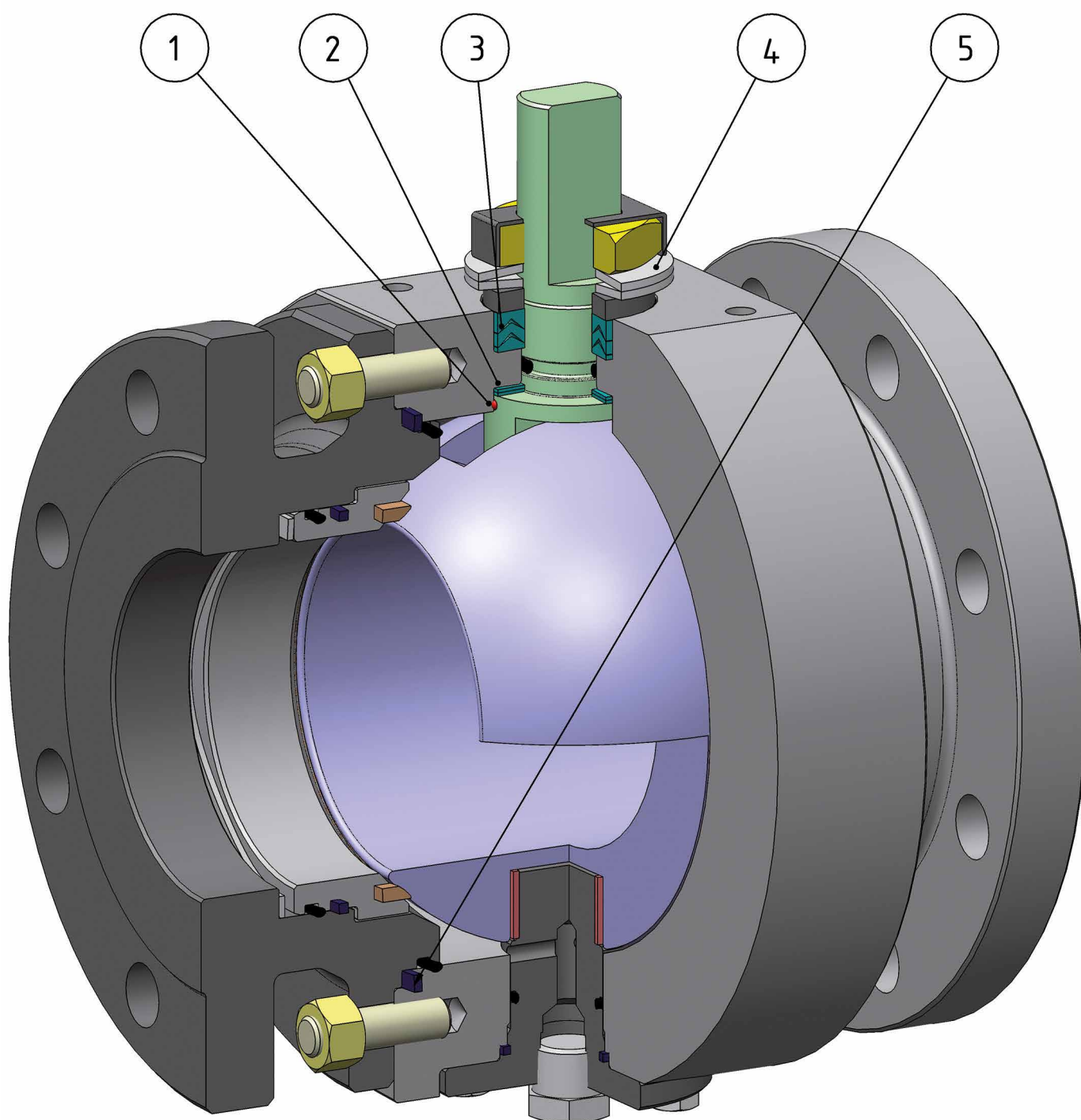



FEATURES & BENEFITS

1	<p>Antistatic device (continuità elettrica tra sfera, stelo e corpo)</p> <p><i>Antistatic device ((electrical continuity between ball, stem and body)</i></p>	<p>Si evitano cariche elettrostatiche che potrebbero essere causa d'innesco in ambienti infiammabili e/o esplosivi</p> <p><i>Static electricity is avoided which can cause sparks and fire in an inflammable/explosive environment</i></p> <p>Sicurezza garantita del contatto durante tutta la vita della valvola</p> <p><i>Contact safety throughout the entire life of the valve</i></p>
2	<p>Doppio anello antifrizione</p> <p><i>Double antifriction washer</i></p>	<p>Garantisce una minor coppia di azionamento della valvola</p> <p><i>Less Break Away Torque is granted</i></p> <p>Minor usura rispetto all'esecuzione con singolo anello</p> <p><i>Less wear comparing with the execution with the single washer</i></p>
3	<p>Pacco guarnizioni a "v" con 3 guarnizioni più o-ring</p> <p><i>"V" seals pack; 3 seals + o-ring</i></p>	<p>Si garantisce una perfetta tenuta anche dopo un numero elevato di cicli</p> <p><i>It ensures a perfect tightness even after a high number of cycles</i></p>
4	<p>Molle a tazza sulla tenuta dello stelo</p> <p><i>Spring washer on the shaft seal</i></p>	<p>Garantiscono il recupero dei giochi dovuti all'usura causata dal movimento semirotatorio dell'albero evitando perdite verso l'esterno</p> <p><i>Guarantee of the recovery of the gap due to the wear caused by the rotational movement of the shaft avoiding leakage towards the outside part.</i></p> <p>Consentono di mantenere energizzate le guarnizioni tipo "chevron" (a V), evitando perdite verso l'esterno, a fronte di notevoli escursioni termiche</p> <p><i>Allow to maintain energized the "chevron" seals (V), thus avoiding any leakage to the outside, against huge temperature excursions</i></p>
5	<p>Tenuta elasticizzata in grafite</p> <p><i>Stretch Graphite seal</i></p>	<p>Garantisce una tenuta verso l'esterno indipendentemente dalle escursioni termiche a cui è sottoposta la valvola</p> <p><i>Tightness towards outside is granted, independently by the thermal excursions to which the valve is subjected</i></p>
	<p>Maggiore precisione nell'allineamento degli assi grazie alla lavorazione dal grezzo al finito con un unico posizionamento</p> <p><i>Greater precision in the alignment of axes due to a unique positioning in the process machining from raw material to finished valve</i></p>	<p>Maggior vita della valvola stessa</p> <p><i>Longer lifetime of the valve</i></p> <p>Minor coppia di azionamento</p> <p><i>Less break away torque</i></p>
	<p>Corpo valvola in acciaio al carbonio realizzato con materiale normalizzato certificato NACE in esecuzione standard</p> <p><i>Valve body in carbon steel made with NACE certified material as standard</i></p>	<p>Garantisce una maggior resistenza alla corrosione</p> <p><i>Greater corrosion resistance</i></p> <p>Maggior duttilità del materiale</p> <p><i>Greater ductility of the material</i></p>
	<p>Processo produttivo interamente eseguito in OMAL</p> <p><i>100% in- house manufacturing process technology</i></p>	<p>Massimo controllo in tutte le fasi di lavorazione</p> <p><i>Maximum control and accuracy in all the stages of the manufacturing process</i></p> <p>Possibilità di fornire rapidamente esecuzioni speciali richieste dal cliente</p> <p><i>Flexibility in supply quickly special executions requested by customers</i></p>
	<p>Certificato "Fire Safe"</p> <p><i>"Fire safe" Certificate</i></p>	<p>Garantisce la tenuta della valvola anche in caso di incendio</p> <p><i>Guarantees the tightness of the valve also in case of fire</i></p>
	<p>Certificato ATEX</p> <p><i>ATEX Certificate</i></p>	<p>Ne consente l'installazione in presenza di ambiente potenzialmente esplosivo</p> <p><i>Installation is possible in a potential explosive environment</i></p>
	<p>Certificazione "TA LUFT fugitive emission"</p> <p><i>TA LUFT fugitive emission Certificate</i></p>	<p>Garantisce un elevato grado di sicurezza della tenuta stelo verso l'esterno</p> <p><i>High level of safety of the tightness towards the outside is granted</i></p>
	<p>Certificato PED</p> <p><i>PED Certificate</i></p>	<p>Piena conformità alle norme di sicurezza europee per i dispositivi in pressione</p> <p><i>Full compliance with European Safety Standards for Pressure Equipment</i></p>
	<p>Certificato fino a SIL 3</p> <p><i>UP to SIL 3 certified</i></p>	<p>Elevato livello di sicurezza funzionale</p> <p><i>Guarantee of the high level of functional safety</i></p>



DN ≤ 100 SIZE ≤ 4" – ANSI ≥ 600

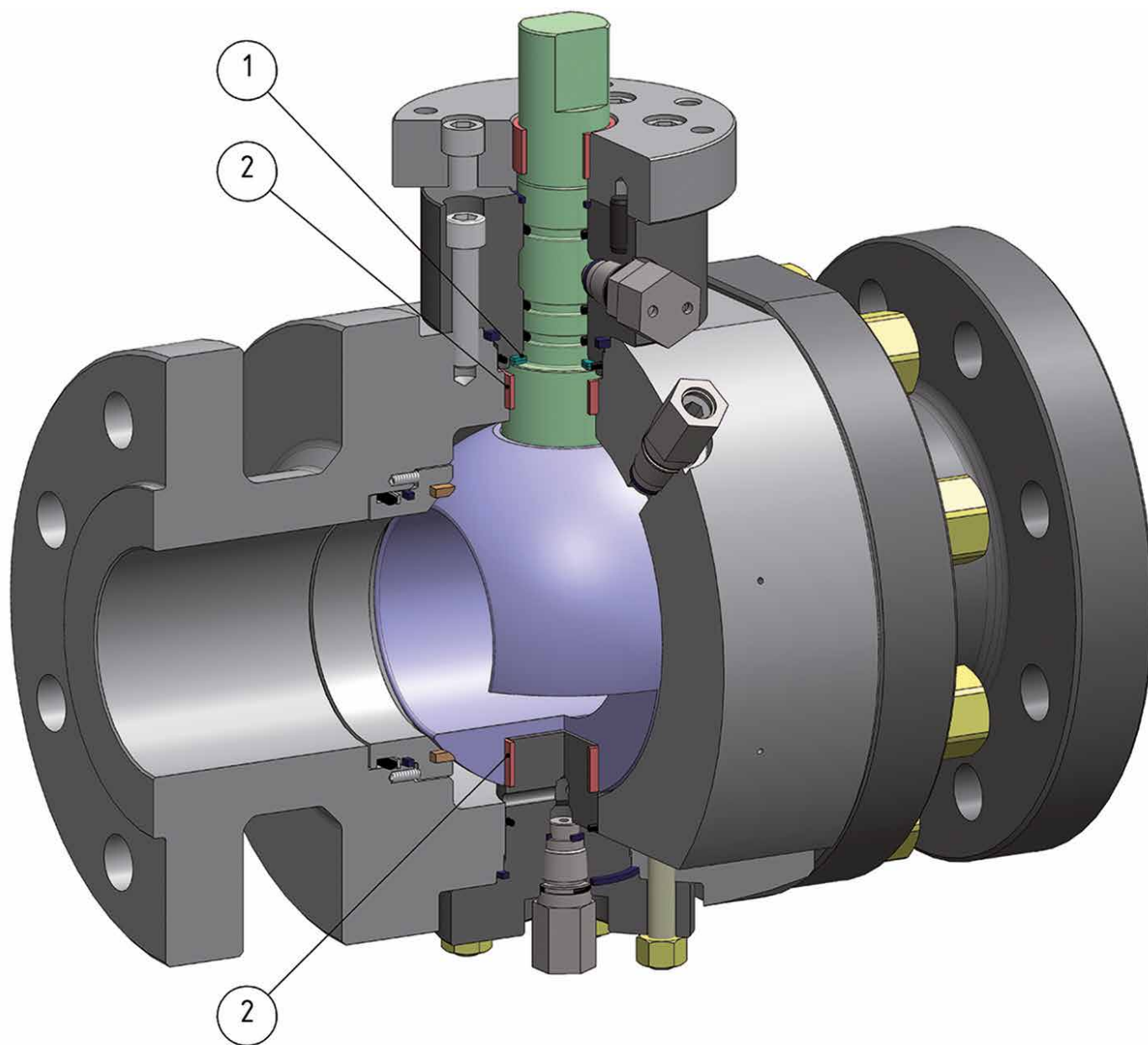



FEATURES & BENEFITS

1	Doppio anello antifrizione <i>Double antifriction washer</i>	Garantisce una minor coppia di azionamento della valvola <i>Less Break Away Torque is granted</i>
		Minor usura rispetto all'esecuzione con singolo anello <i>Less wear comparing with the execution with the single washer</i>
2	Doppie boccole di guida sfera <i>Two ball guiding bushings</i>	Diminuiscono la coppia torcente della valvola <i>Less valve torque</i>
	Antistatic device (continuità elettrica tra sfera, stelo e corpo) <i>Antistatic device ((electrical continuity between ball, stem and body)</i>	Si evitano cariche elettrostatiche che potrebbero essere causa d'innescio in ambienti infiammabili e/o esplosivi <i>Static electricity is avoided which can cause sparks and fire in an inflammable/explosive environment</i>
		Sicurezza garantita del contatto durante tutta la vita della valvola <i>Contact safety throughout the entire life of the valve</i>
	Tenuta elasticizzata in grafite <i>Stretch Graphite seal</i>	Garantisce una tenuta verso l'esterno indipendentemente dalle escursioni termiche a cui è sottoposta la valvola <i>Tightness towards outside is granted, independently by the thermal excursions to which the valve is subjected</i>
	Corpo valvola in acciaio al carbonio realizzato con materiale normalizzato certificato NACE in esecuzione standard <i>Valve body in carbon steel made with NACE certified material as standard</i>	Garantisce una maggior resistenza alla corrosione <i>Greater corrosion resistance</i>
		Maggior duttilità del materiale <i>Greater ductility of the material</i>
	Certificato "Fire Safe" <i>"Fire safe" Certificate</i>	Garantisce la tenuta della valvola anche in caso di incendio <i>Guarantees the tightness of the valve also in case of fire</i>
	Certificato ATEX <i>ATEX Certificate</i>	Ne consente l'installazione in presenza di ambiente potenzialmente esplosivo <i>Installation is possible in a potential explosive environment</i>
	Certificato PED <i>PED Certificate</i>	Piena conformità alle norme di sicurezza europee per i dispositivi in pressione <i>Full compliance with European Safety Standards for Pressure Equipment</i>
	Certificato fino a SIL 3 <i>UP to SIL 3 certified</i>	Elevato livello di sicurezza funzionale <i>Guarantee of the high level of functional safety</i>



DN ≥ 150 SIZE ≥ 6"

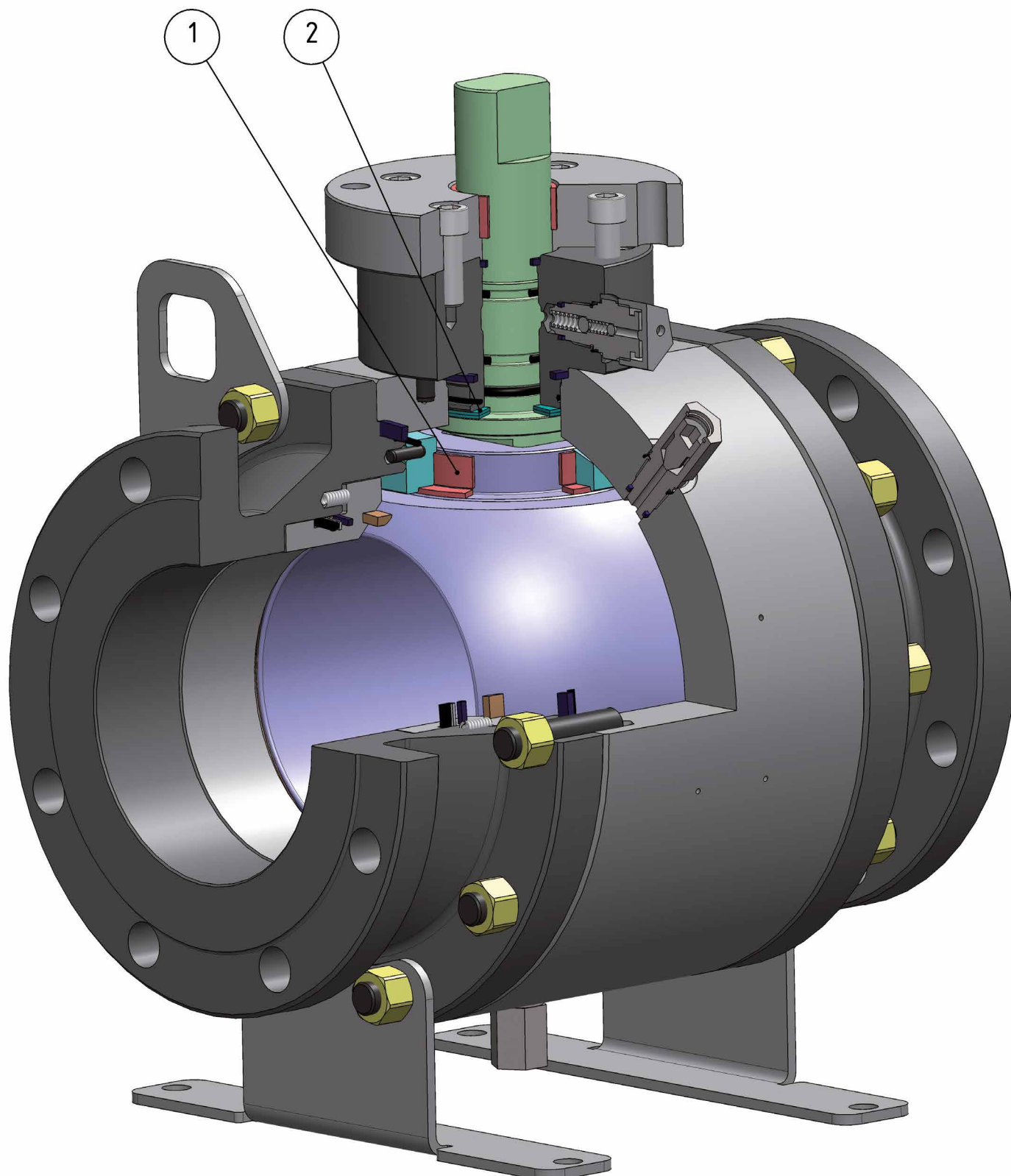



FEATURES & BENEFITS

1	Doppio anello antifrizione <i>Double antifriction washer</i>	Garantisce una minor coppia di azionamento della valvola <i>Less Break Away Torque is granted</i>
		Minor usura rispetto all'esecuzione con singolo anello <i>Less wear comparing with the execution with the single washer</i>
2	Doppie boccole di guida sfera <i>Two ball guiding bushings</i>	Diminuiscono la coppia torcente della valvola <i>Less valve torque</i>
	Antistatic device (continuità elettrica tra sfera, stelo e corpo) <i>Antistatic device ((electrical continuity between ball, stem and body)</i>	Si evitano cariche elettrostatiche che potrebbero essere causa d'innescio in ambienti infiammabili e/o esplosivi <i>Static electricity is avoided which can cause sparks and fire in an inflammable/explosive environment</i>
		Sicurezza garantita del contatto durante tutta la vita della valvola <i>Contact safety throughout the entire life of the valve</i>
	Tenuta elasticizzata in grafite <i>Stretch Graphite seal</i>	Garantisce una tenuta verso l'esterno indipendentemente dalle escursioni termiche a cui è sottoposta la valvola <i>Tightness towards outside is granted, independently by the thermal excursions to which the valve is subjected</i>
	Corpo valvola in acciaio al carbonio realizzato con materiale normalizzato certificato NACE in esecuzione standard <i>Valve body in carbon steel made with NACE certified material as standard</i>	Garantisce una maggior resistenza alla corrosione <i>Greater corrosion resistance</i>
		Maggior duttilità del materiale <i>Greater ductility of the material</i>
	Certificato "Fire Safe" <i>"Fire safe" Certificate</i>	Garantisce la tenuta della valvola anche in caso di incendio <i>Guarantees the tightness of the valve also in case of fire</i>
	Certificato ATEX <i>ATEX Certificate</i>	Ne consente l'installazione in presenza di ambiente potenzialmente esplosivo <i>Installation is possible in a potential explosive environment</i>
	Certificato PED <i>PED Certificate</i>	Piena conformità alle norme di sicurezza europee per i dispositivi in pressione <i>Full compliance with European Safety Standards for Pressure Equipment</i>
	Certificato fino a SIL 3 <i>UP to SIL 3 certified</i>	Elevato livello di sicurezza funzionale <i>Guarantee of the high level of functional safety</i>
	Certificazione FUGITIVE EMISSION <i>FUGITIVE EMISSION Certificate</i>	Garantisce un elevato grado di sicurezza della tenuta stelo verso l'esterno <i>High level of safety of the tightness towards the outside is granted</i>



SUPREME - TRUNNION

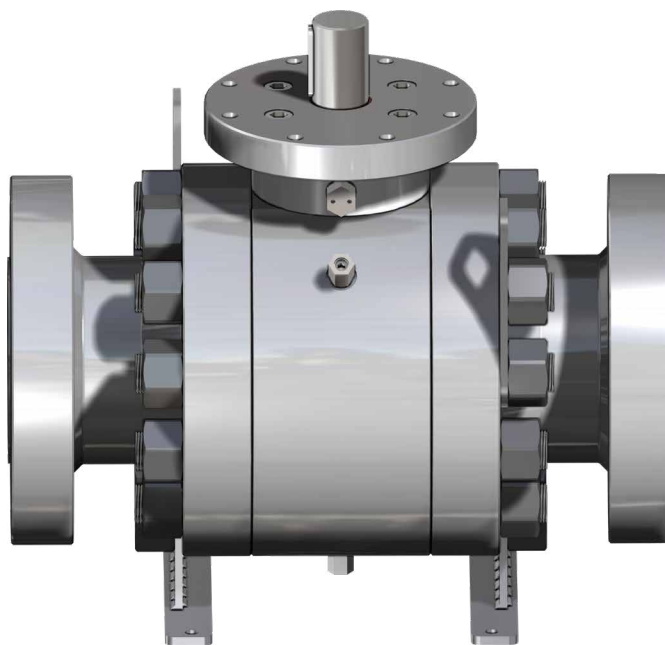

ESECUZIONE STANDARD

- Corpo in due o tre pezzi.
- Seggi di tenuta resilienti.
- Scarico automatico della sovrappressione nel corpo.
- Double Block & Bleed.
- Classi di pressione: ANSI 150÷ANSI 2500.
- Applicazioni: impianti chimici e petrolchimici, centrali elettriche ed altre applicazioni nell'industria di processo per liquidi, gas, vapore ed idrocarburi.
- Stelo anti espulsione.

ESECUZIONI SPECIALI A RICHIESTA

- Doppio effetto pistone.
- Materiali ed esecuzioni speciali in accordo alle specifiche del cliente.
- Marcatura e certificato ATEX A RICHIESTA.

CERTIFICAZIONI

- Conforme alla Direttiva Europea 2014/68/UE PED.
- Conforme alla Direttiva Europea 2014/34/UE ATEX. (certificato ATEX A RICHIESTA).
- Livello di sicurezza funzionale fino a SIL 3 in accordo a IEC 61508.
- FIRE SAFE EN ISO 10497- API607.
- Fugitive Emission UNI EN ISO 15848.

STANDARD DI PROGETTO

- ASME B16.34.
- Estremità: ASME B16.5 (RF-RTJ), ASME B16.25 (BW).
- Scartamento: ASME B16.10.
- Flangia per il montaggio azionamento: ISO5211.
- Design API 6D a richiesta.

STANDARD EXECUTION

- *Two or three pieces body.*
- *Resilient seat.*
- *Automatic body cavity relief.*
- *Double Block & Bleed.*
- *Pressure class: ANSI 150÷ANSI 2500.*
- *Applications: chemical and petrochemical plants, oil & gas production, power plants, other process industry applications, liquid, gas and steam, hydrocarbons.*
- *Anti blow out stem.*

SPECIAL FEATURES ON REQUEST

- *Double piston effect.*
- *Material and special execution according to Customer Specifications.*
- *ATEX marking and certificate ON REQUEST.*

CERTIFICATIONS

- *In compliance with European Directive 2014/68/EU PED.*
- *In compliance with European Directive 2014/34/EU ATEX (ATEX certificate ON REQUEST).*
- *Safety integrity level up to SIL 3 according to IEC 61508.*
- *FIRE SAFE EN ISO 10497- API607.*
- *Fugitive Emission UNI EN ISO 15848.*

STANDARD DESIGN

- *ASME B16.34.*
- *End connections: ASME B16.5 (RF-RTJ), ASME B16.25 (BW).*
- *Face to face: ASME B16.10.*
- *Drives mounting flange: ISO5211.*
- *Design API 6D on request.*



TAGLIE E ACCESSORI SIZE AND ACCESSORIES

DN	50	80 x 65	80	100 x 80	100	150 x 100	150	200 x 150	200	250 x 200	250	300 x 250	300	350 x 250	350	400 x 300	400	450 x 350	450	500 x 400	500	600 x 500	600	
SIZE	2"	3" x 2 1/2"	3"	4" x 3"	4"	6" x 4"	6"	8" x 6"	8"	10" x 8"	10"	12" x 10"	12"	14" x 10"	14"	16" x 12"	16"	18" x 14"	18"	20" x 16"	20"	24" x 20"	24"	
ANSI 150	A																							
	B	•	•	•	•	•																		
	C																							
	D																							
	E																							
	F																							
ANSI 300	A																							
	B	•	•	•	•	•																		
	C																							
	D																							
	E																							
	F																							
ANSI 600	A	•	•	•	•	•	•	•	•	•	•	•	•	•	•	•	•	•	•	•	•	•	•	•
	B	•	•	•	•	•	•	•	•	•	•	•	•	•	•	•	•	•	•	•	•	•	•	•
	C	•	•	•	•	•	•	•	•	•	•	•	•	•	•	•	•	•	•	•	•	•	•	•
	D																							
	E																							
	F																							
ANSI 900	A	•	•	•	•	•	•	•	•	•	•	•	•	•	•	•	•	•	•	•	•	•	•	•
	B	•	•	•	•	•	•	•	•	•	•	•	•	•	•	•	•	•	•	•	•	•	•	•
	C	•	•	•	•	•	•	•	•	•	•	•	•	•	•	•	•	•	•	•	•	•	•	•
	D																							
	E																							
	F																							
ANSI 1500	A	•	•	•	•	•	•	•	•	•	•	•	•	•	•	•	•	•	•	•	•	•	•	•
	B	•	•	•	•	•	•	•	•	•	•	•	•	•	•	•	•	•	•	•	•	•	•	•
	C	•	•	•	•	•	•	•	•	•	•	•	•	•	•	•	•	•	•	•	•	•	•	•
	D																							
	E																							
	F																							
ANSI 2500	A	•	•	•	•	•	•	•	•	•	•	•	•	•	•	•	•	•	•	•	•	•	•	•
	B	•	•	•	•	•	•	•	•	•	•	•	•	•	•	•	•	•	•	•	•	•	•	•
	C	•	•	•	•	•	•	•	•	•	•	•	•	•	•	•	•	•	•	•	•	•	•	•
	D																							
	E																							
	F																							

SUPREME

- A) Ingrassatore stelo *Shaft Sealing Injection*
- B) Tappo corpo/coperchio inferiore *Vent and Drain Plug*
- C) Valvola di drenaggio corpo/coperchio inferiore *Vent and Drain valves*
- D) Ingrassatore seggi *Seats Sealing Injection*
- E) Asole sollevamento *Lifting lug*
- F) Piedi di supporto *Supporting feet*

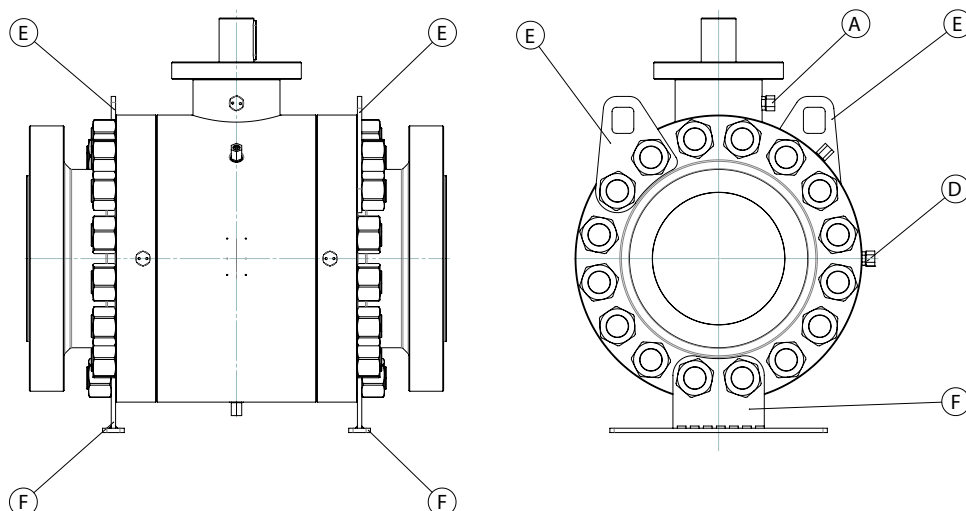



ACCESSORI ACCESSORIES

A Ingrassatore Stelo
Shaft Stem Injection / Sealant system

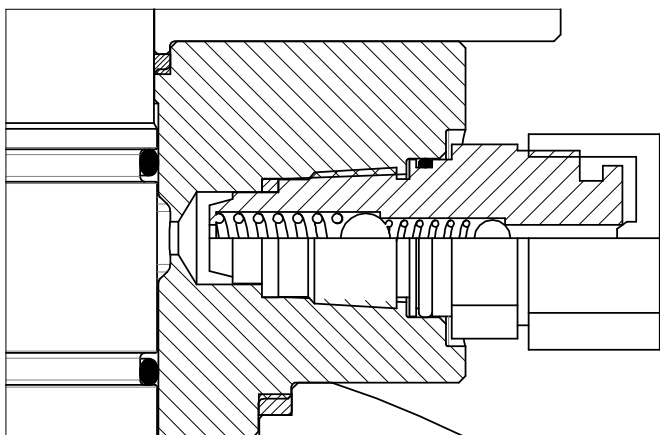

B Tappo corpo / Coperchio inferiore
Vent and Drain Plug

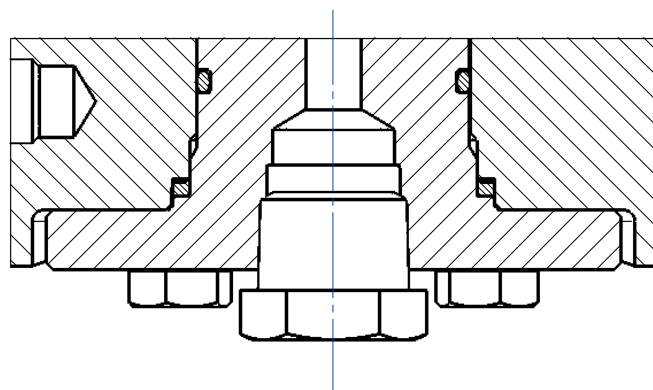

C Valvola di drenaggio corpo / coperchio inferiore
Vent and Drain valves

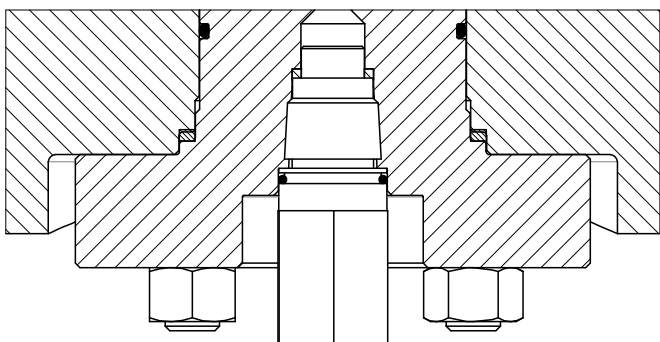

D Ingrassatore Seggio
Seat Stem Injection / Sealant system

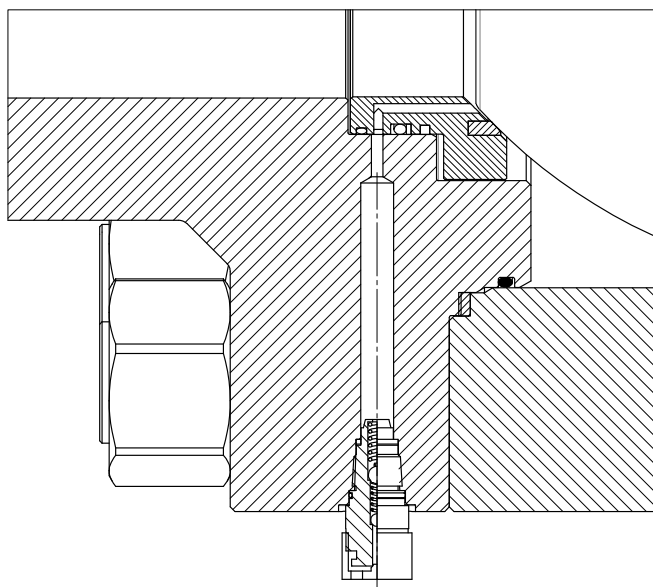



COMPONENTI COMPONENTS

DN≤100 SIZE ≤4" – ANSI 150-300



TABELLA DEI COMPONENTI COMPONENTS TABLE

1	Corpo <i>Body</i>	10	O-ring porta seggio <i>Seat O-ring</i>	19	Anello premi guarnizioni <i>Gland nut ring</i>
2	Terminale <i>Closure</i>	11	Anello antiestrusione <i>Back-up ring</i>	20	Molle a tazza <i>Spring washer</i>
3	Sfera <i>Ball</i>	12	Guarnizione seggio <i>Seat gasket</i>	21	Dado stelo <i>Stem nut</i>
4	Stelo <i>Stem</i>	13	Molle precarico seggio <i>Springs</i>	22	Ferma dado <i>Stem nut locker</i>
5	Seggio <i>Seat insert</i>	14	Tiranti <i>Stud bolt</i>	23	Viti coperchio inferiore <i>Lower cover screws</i>
6	Porta seggio <i>Seat holder</i>	15	Dadi <i>Nut</i>	24	Guarnizione coperchio inferiore <i>Lower cover gasket</i>
7	Coperchio inferiore <i>Lower cover</i>	16	Anelli antifrizione <i>Bottom sealing</i>	25	O-ring cop inferiore <i>Lower cover O-ring</i>
8	O-ring corpo <i>Body O-ring</i>	17	O-ring stelo <i>Stem O-ring</i>	26	Tappo <i>Drain cap</i>
9	Guarnizione corpo <i>Body gasket</i>	18	Pacco guarnizioni v <i>Chevron pack</i>		



DN≤100 SIZE ≤4" – ANSI ≥600

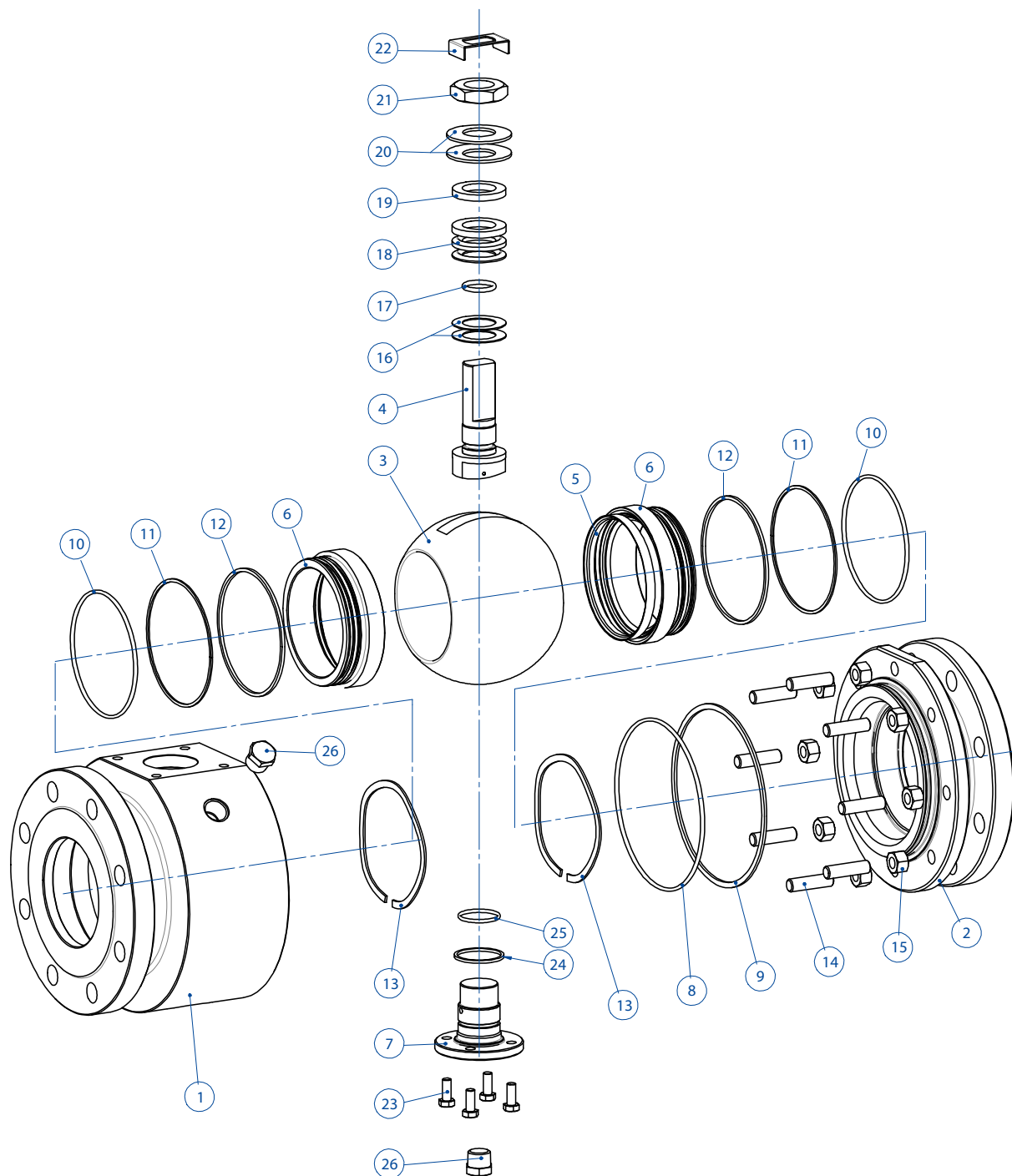

TABELLA COMPONENTI COMPONENTS TABLE

1 Corpo <i>Body</i>	14 Anello antiestrusione <i>Back-up ring</i>	27 Boccola stelo <i>Stem bush</i>
2 Terminale <i>Closure</i>	15 O-ring seggio <i>Seat O-ring</i>	28 Viti flangia <i>Flange screw</i>
3 Sfera <i>Ball</i>	16 Guarnizione seggio <i>Seat gasket</i>	29 Spine centraggio <i>Body pin</i>
4 Stelo <i>Stem</i>	17 Tiranti <i>Stud bolt</i>	30 Boccola sfera <i>Ball bush</i>
5 Seggio <i>Seat insert</i>	18 Dadi <i>Nut</i>	31 O-ring coperchio inferiore <i>Lower cover O-ring</i>
6 Porta seggio <i>Seat holder</i>	19 Boccola sfera <i>Ball bush</i>	32 Guarnizione coperchio inferiore <i>Lower cover gasket</i>
7 Coperchio superiore <i>Upper cover</i>	20 Anello antifrizione <i>Bottom sealing</i>	33 Tiranti/viti coperchio inferiore <i>Lower cover stud</i>
8 Flangia <i>Flange</i>	21 O-ring stelo <i>Stem O-ring</i>	34 Dadi <i>Nut</i>
9 Coperchio inferiore <i>Lower cover</i>	22 O-ring coperchio superiore <i>Upper cover O-ring</i>	35 Valvola drenaggio <i>Vent valve</i>
10 Guarnizione corpo <i>Body gasket</i>	23 Guarnizione coperchio superiore <i>Upper cover Gasket</i>	36 Ingrassatore stelo <i>Stem grease injector</i>
11 O-ring corpo <i>Body O-ring</i>	24 Spina centraggio <i>Upper cover pin</i>	37 O-ring ingrassatore/valvola drenaggio <i>Vent/Greaser O-ring</i>
12 Molla dispositivo antistatico <i>Antistatic device Spring</i>	25 Guarnizione fire safe/dispositivo antistatico <i>Fire safe stem Gasket/antistatic device</i>	38 Guarnizione ingrassatore/valvola drenaggio <i>Vent/Greaser Gasket</i>
13 Molle precarico seggio <i>Springs</i>	26 Viti coperchio superiore <i>Upper cover screw</i>	



DN ≥150 SIZE ≥6"

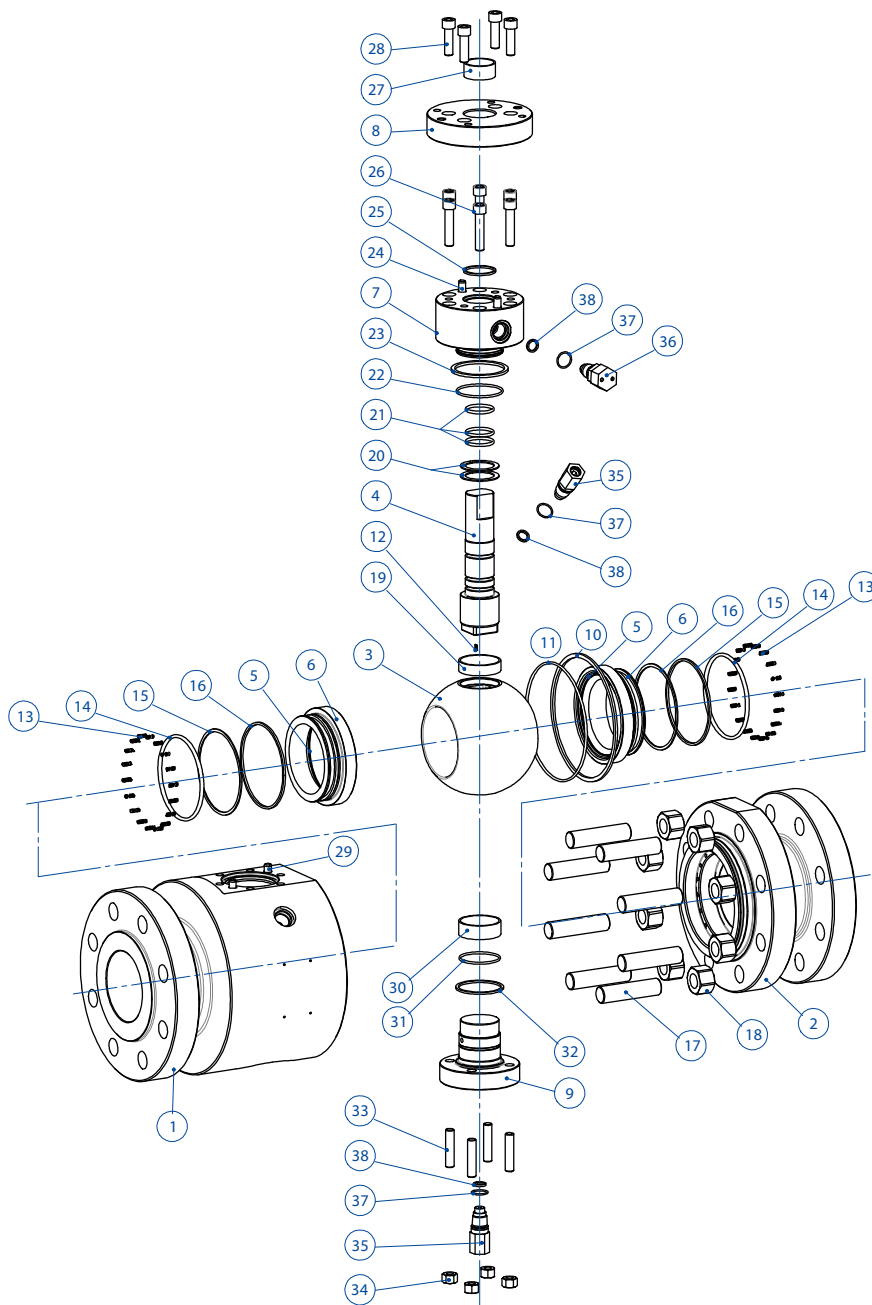

TABELLA DEI COMPONENTI COMPONENTS TABLE

1	Corpo <i>Body</i>	14	Anello antiestrusione <i>Back-up ring</i>	27	Boccola stelo <i>Stem bush</i>
2	Terminale <i>Closure</i>	15	Guarnizione porta seggio <i>Seat gasket</i>	28	Viti flangia <i>Flange screw</i>
3	Sfera <i>Ball</i>	16	Tiranti <i>Stud bolt</i>	29	Spine centraggio <i>Upper cover pin</i>
4	Stelo <i>Stem</i>	17	Dadi <i>Nut</i>	30	Asole sollevamento <i>Lifting Lug</i>
5	Seggio <i>Seat insert</i>	18	Boccola sfera <i>Ball bush</i>	31	Piedi di supporto <i>Support feet</i>
6	Porta seggio <i>Seat holder</i>	19	Ralla sfera <i>Thrust bearing</i>	32	Spine centraggio <i>Body pin</i>
7	Coperchio superiore <i>Upper cover</i>	20	Spine centraggio <i>Support plate pin</i>	33	Ingrassatore stelo <i>Stem grease injector</i>
8	Flangia <i>Flange</i>	21	Anelli antifrizione <i>Bottom sealing</i>	34	Valvola di drenaggio <i>Vent valve</i>
9	Piastre supporto <i>Support plate</i>	22	O-ring coperchio superiore <i>Upper cover O-ring</i>	35	O-ring valvola drenaggio/ingrassatore <i>Vent/Greaser O-ring</i>
10	Guarnizione corpo <i>Body gasket</i>	23	Guarnizione coperchio superiore <i>Upper cover Gasket</i>	36	Guarnizione valvola drenaggio/ingrassatore <i>Vent/Greaser Gasket</i>
11	O-ring corpo <i>Body O-ring</i>	24	O-ring stelo <i>Stem O-ring</i>	37	Dispositivo antistatico <i>Antistatic device spring</i>
12	Molle precarico seggio <i>Springs</i>		Guarnizione fire safe/dispositivo antistatico <i>Fire safe stem Gasket/antistatic device</i>		
13	O-ring porta seggio <i>Seat O-ring</i>	26	Viti coperchio superiore <i>Upper cover screw</i>		

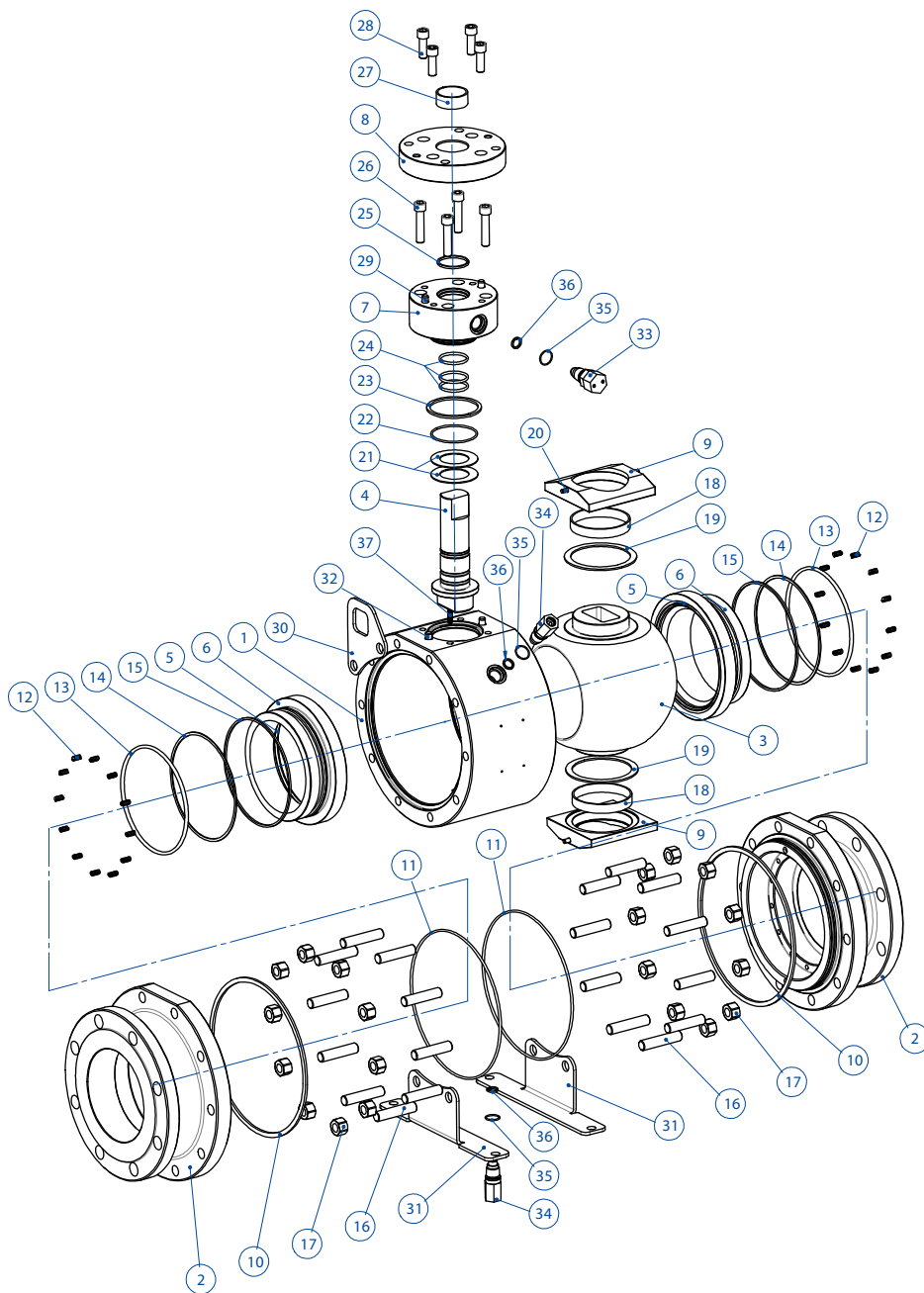

DIMENSIONI VALVOLE PASSAGGIO TOTALE FULL BORE VALVES - DIMENSIONS

DN ≤ 100 SIZE ≤ 4"
ANSI 150-300

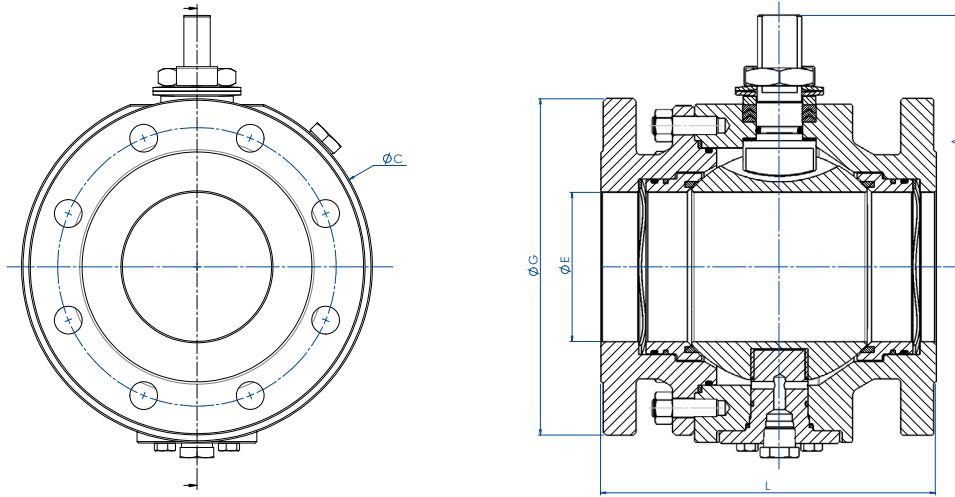

DN ≤ 100 SIZE ≤ 4"
ANSI ≥ 600

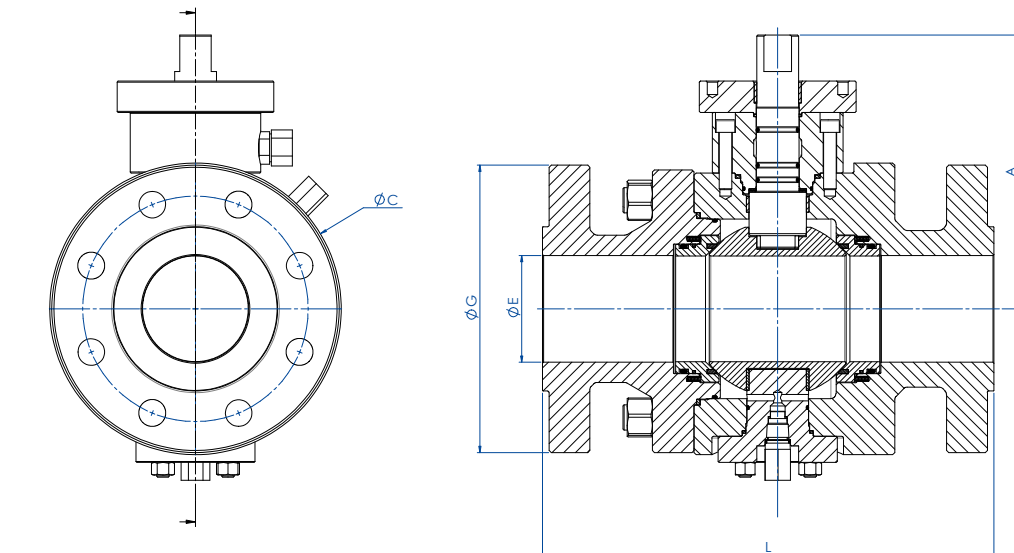

DN ≥ 150 SIZE ≥ 6"

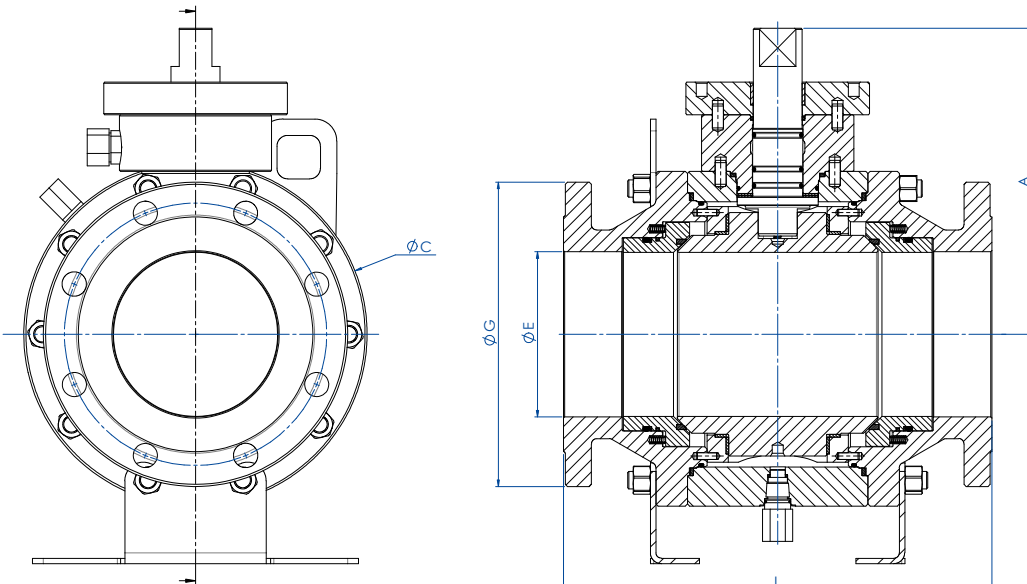



ANSI 150	DN	SIZE	L	ØE	ØG	A	ØC
	50	2"	178	51	152	67*	146*
	80	3"	203	76	190	90	190
	100	4"	229	102	230	111	240
	150	6"	394	152	280	232	316
	200	8"	457	203	345	286	400
	250	10"	533	254	408	324	475
	300	12"	610	305	484	355*	580*
	350	14"	686	337	536	402*	626*
	400	16"	762	386	397	441*	700*
	450	18"	864	438	636	484*	779*
	500	20"	914	489 *	694	560*	900*
	600	24"	1067	591 *	814	620*	1020*

ANSI 300	DN	Size	L	ØE	ØG	A	ØC
	50	2"	216	51	165	67*	156*
	80	3"	282	76	210	90	200
	100	4"	305	102	255	111	240
	150	6"	403	152	320	236	324
	200	8"	502	203	382	286	408
	250	10"	568	254	446	324	475
	300	12"	648	305	522	355*	580*
	350	14"	762	337	585	402*	626*
	400	16"	838	386	649	504*	770*
	450	18"	914	438	712	484*	779*
	500	20"	991	489 *	776	560*	900*
	600	24"	1143	591 *	915	620*	1020*

ANSI 600	DN	Size	L	ØE	ØG	A	ØC
	50	2"	292	51	165	160*	189*
	80	3"	356	76	210	191	210
	100	4"	432	102	275	218	279
	150	6"	559	152	355	263	355
	200	8"	660	203	420	304	430
	250	10"	787	254	510	352	520
	300	12"	838	305	561	402*	620*
	350	14"	889	337	604	416*	655*
	400	16"	991	386	687	450*	730*
	450	18"	1092	438	744	515*	810*
	500	20"	1194	489 *	814	588*	955*
	600	24"	1397	591*	941	645*	1070*

ANSI 900	DN	Size	L	ØE	ØG	A	ØC
	50	2"	368	51	215	120*	189*
	80	3"	381	76	242	204	240
	100	4"	457	102	293	218	279
	150	6"	610	152	382	263	355
	200	8"	737	203	471	304	430
	250	10"	838	254	547	352	520
	300	12"	965	305	612	452	660
	350	14"	1029	322	640	460*	700*
	400	16"	1130	373	706	485*	760*

ANSI 1500	DN	Size	L	ØE	ØG	A	ØC
	50	2"	368	51	215	140*	189*
	80	3"	470	76	268	225	270
	100	4"	546	102	312	240*	300*
	150	6"	705	146	395	285*	390*
	200	8"	832	192	485	340*	460*
250	10"	991	239	585	390*	555*	

ANSI 2500	DN	Size	L	ØE	ØG	A	ØC
	50	2"	451	42	235	160	219
	80	3"	508	63	305	241	318
	100	4"	673	87	357	253	335
150	6"	914	131	485	340	500	



AZIONAMENTI DISPONIBILI AVAILABLE DRIVERS

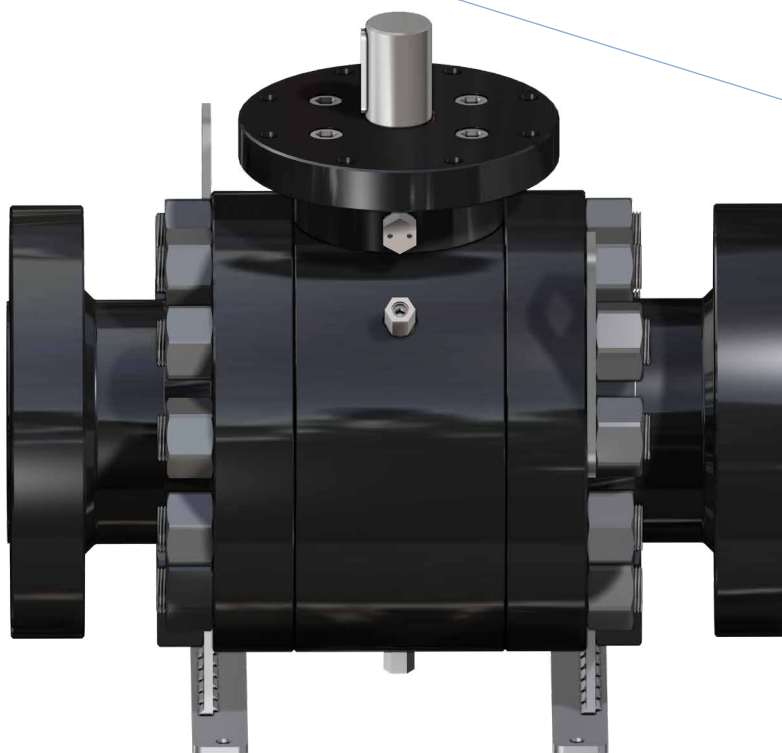
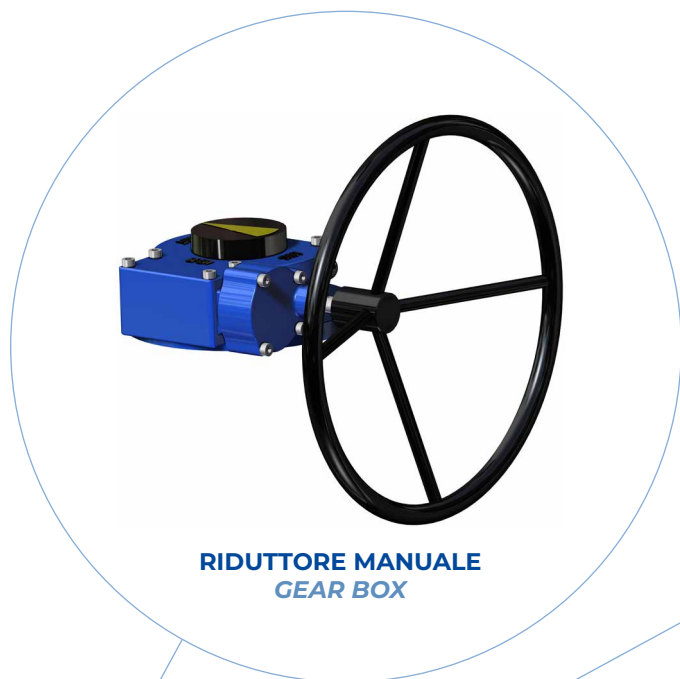

Le immagini sono indicative e non sono vincolanti ai fini della fornitura *The images are only representative and they are not binding for supply purpose*



ATTUATORE PNEUMATICO
PNEUMATIC ACTUATOR



ATTUATORE PNEUMATICO CON
COMANDO MANUALE INTEGRATO
PNEUMATIC ACTUATOR WITH
INTEGRATED HANDWHEEL

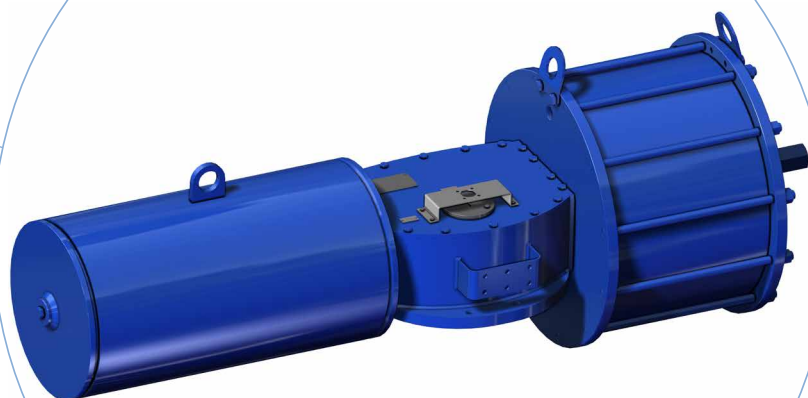

ATTUATORE PNEUMATICO HEAVY DUTY
HEAVY DUTY PNEUMATIC ACTUATOR





Certificate of Authority to use the Official API Monogram

License Number: 6D-1007 **ORIGINAL**

The American Petroleum Institute hereby grants to

OMAL SPA
Via Ponte Nuovo, 11
Rodengo Saiano, Brescia
Italy

the right to use the Official API Monogram® on manufactured products under the conditions in the official publications of the American Petroleum Institute entitled API Spec Q1® and **API-6D** and in accordance with the provisions of the License Agreement.

In all cases where the Official API Monogram is applied, the API Monogram shall be used in conjunction with this certificate number: **6D-1007**

The American Petroleum Institute reserves the right to revoke this authorization to use the Official API Monogram for any reason satisfactory to the Board of Directors of the American Petroleum Institute.

The scope of this license includes the following: Ball Valves

QMS Exclusions: No Exclusions Identified as Applicable

Effective Date: AUGUST 13, 2022
Expiration Date: AUGUST 13, 2025

Anchal Liddar
Senior Vice President of Global Industry Services

To verify the authenticity of this license, go to www.api.org/compositelist.

▲ API 6D

Certificazione del Sistema di Qualità applicato per la progettazione, fabbricazione, ispezione finale e la prova di valvole a sfera per impianti del settore del petrolio e dal gas naturale in accordo allo standard API6D ed autorizzazione all'applicazione del Monogramma API da parte dell'American Petroleum Institute.

Certification of the Quality Management System operated by OMAL for the design, manufacture, final inspection and tests of ball valves for installations in the sector of oil and natural gas according to the API6D Spec. and license by American Petroleum Institute to the API monogram application.



CERTIFICATE

This certifies, that the company

Omial S.p.A.
Via Ponte Nuovo, 11
25050 Rodengo Saiano (BS)
Italy

Is authorized to provide the product mentioned below

Description of product: **2-ways split body trunnion mounted ball valve series Supreme**

In accordance with: **EN 61508:2010 Parts 1, 2, 3, 4, 5, 6, 7**

Registration No 20 20034 01
Test Report No FS-20034-20-L-01
File reference: 20034-01



TUV NORD Italia S.p.A. (TUV NORD Group)
Via Turati, 10 20023 Cerro Maggiore (MI) www.tuv-nord.it

Validity from: 2020-07-29
until: 2023-07-29

Cerro Maggiore, 2020-07-29
prodotto@tuv-nord.it

Please also pay attention to the information stated overleaf

▲ SIL

Certificazione di conformità alla norma IEC 61508, del livello di sicurezza funzionale del prodotto destinato ad essere integrato in sistemi con un livello di integrità funzionale fino a SIL 3.

Certification of compliance to the IEC 61508 requirements, of the functional safety level provided by the product intended to be integrated in systems with required safety integrity level up to SIL 3.





Appareil non électrique destiné à être utilisé en atmosphères explosibles
Non electrical equipment intended for use in potentially explosive atmospheres
Apparecchi non elettrici destinati ad essere utilizzati in atmosfera potenzialmente esplosiva

Directive 2014/34/EU
Directive 2014/34/UE / Direttiva 2014/34/UE

ACCUSÉ DE RECEPTION D'UN DOSSIER TECHNIQUE
ACKNOWLEDGE RECEIPT OF TECHNICAL DOCUMENTATION
AVVISO DI RICEVIMENTO DEL FASCICOLO TECNICO

Appareil / Equipment / Apparecchiatura: **BALL VALVES**

Type(s) / Type(s) / Tipi(i): Wafer type, Split body type, Split Wafer type steel ball valves / Two-piece, Three-piece steel ball valve High-pressure - threaded ends / Two-piece brass ball valves threaded ends

Marquage / Marking / Marcatura:  II 2 GD

Dépositaire / Applicant / Richiedente: **OMAL S.p.A.**
Via Ponte Nuovo 11

I: 25050 Rodengo Saiano (BS)

L'INERIS, organisme notifié et identifié sous le numéro 0080, conformément aux articles 17 et 21 de la Directive du Conseil 2014/34/UE du 26 février 2014, accuse réception du dossier conformément à la procédure décrite au chapitre 3, article 13 b) ii) de la Directive.

L'INERIS, notified body and identified under number 0080, in accordance with articles 17 and 21 of Council Directive 2014/34/UE of the 26 February 2014, acknowledges receipt of file according to the procedure described in chapter 3, article 13 b) ii) of the Directive.

L'INERIS, organismo notificato e identificato con il n.0080 conformemente agli articoli 17 e 21 della Direttiva 2014/34/UE del 26 febbraio 2014, conferma il ricevimento del fascicolo alla procedura prevista nella rubrica 3, articolo 13 b) ii) della Direttiva.

La documentation technique référencée: VS-19 dated 10/10/2019	The technical documentation referenced: VS-19 dated 10/10/2019	La documentazione tecnica di riferimento: VS-19 datata 10/10/2019
est consignée sous le numéro d'enregistrement:	is consigned under the reference:	è depositata con il numero di registrazione:
n° INERIS-EQEN 035241/19.	no INERIS-EQEN 035241/19.	n° INERIS-EQEN 035241/19.
Dans le cadre de cet enregistrement, l'INERIS n'a pas examiné le contenu de la documentation technique.	Within the scope of the recording, INERIS did not examine the content of the technical documentation.	Nel quadro di questa registrazione, l'INERIS non ha esaminato il contenuto della documentazione tecnica.
Date de fin de validité: 2025.11.07	Validity completion date: 2025.11.07	Data di fine di validità: 2025.11.07

Le Directeur Général de l'INERIS, Par délégation, The Chief Executive Officer of INERIS, By delegation, Il Direttore generale dell'INERIS, Per delega,

Ce document ne peut être reproduit que dans son intégralité / Only the entire document may be reproduced / Questo documento può essere riprodotto solo integralmente
Par: Technologie Alata BP 2 F-69500 Vernueil-en-Halatte
tél +33(0)3 44 55 46 77 fax +33(0)3 44 54 46 99 internet www.ineris.fr
Institut national de l'environnement industriel et des risques
Etablissement public à caractère industriel et commercial - RCS Compilongne B 381 964 924 - Siret 381 964 921 00019 - APE 7120B - TVA Intracom FR 73 381 964 921

▲ ATEX

Dichiarazione che il Sistema di Qualità applicato per la progettazione, fabbricazione, ispezione finale e la prova di valvole industriali è in accordo con i requisiti della Direttiva ATEX per apparecchiature destinate all'impiego in ambienti con atmosfera potenzialmente esplosiva.

Declaration that the Quality Management System operated by OMAL for the design, manufacture, final inspection and tests of industrial valves is in compliance with the Directive ATEX for equipment intended to be used in potentially explosive atmospheres.



OMAL S.p.A.



Ph. +39 030 8900145 - Fax +39 030 8900423 - info@omal.it - www.omal.com

HEADQUARTERS

Via Ponte Nuovo, 11 - 25050 Rodengo Saiano (BS) ITALY

Coordinates:

Lat: 45° 35' 53" North; Lon: 10° 05' 21" East

PRODUCTION SITE

Via Brognolo, 12 - 25050 Passirano (BS) ITALY

Coordinates:

Lat: 45° 35' 51" North; Lon: 10° 05' 18" East